

TP40201 Data Sheet
Copyright © SIGMATONE
Version 1.0

Disclaimer

Information contained in this data sheet regarding device applications is provided only for your convenience and may be superseded by updates. Sigmatone makes no representations or warranties with respect to the accuracy or completeness of the information furnished in this data sheet. This information is not intended as a warranty and Sigmatone does not assume responsibility for its use. Sigmatone reserves right to change circuitry, specifications and descriptions at any time without notice. No license, whether express, implied, arising by estoppel or otherwise, to any intellectual property rights is granted by this document. Sigmatone disclaims any express or implied warranty relating to the sale and/or use of Sigmatone products including liability or warranties relating to fitness for a particular purpose, merchantability, or infringement of any patent, copyright or other intellectual property right. Sigmatone Products are not designed or authorized for use as components in life support appliances, devices or systems where malfunction of a product can reasonably be expected to result in personal injury. A Purchaser's use or sale of Sigmatone Products for use in life support appliances, devices or systems is a Purchaser's own risk and Purchaser agrees to fully indemnify Sigmatone for any damages resulting from such use or sale and hold harmless Sigmatone from any and all damages, claims, suits, or expenses resulting from such use.

Preface

This data sheet specifies the board layout, interface, power supply and other information for CapTouCon TP40201. Some of the CapTouCon TP40201 features are explained using other CapTouCon devices.

In this document all numbers are decimal notation except for those preceded by '0x', such numbers are in hexadecimal notation.

Note and Caution

NOTE : Notes are attention to important information.

CAUTION : Cautions are included to avoid damaging hardware.

Table of Contents

Preface.....	3
1 CapTouCon Board TP40201.....	5
2 Specification	5
3 Interface Header.....	6
4 Functionality.....	7
5 Header Interface.....	8
6 SPI and Header Interface	9
7 Interrupt.....	10
8 SPI Daisy Chain.....	11
9 Sensitivity Control.....	14
10 TP Extension.....	14
11 MODE.....	15
12 Buzzer.....	16
13 Timing Waveforms.....	18
14 Timing Waveforms (Daisy Chain).....	19
15 FAQ.....	21
16 Support/Feedback.....	22

1 CapTouCon Board TP40201

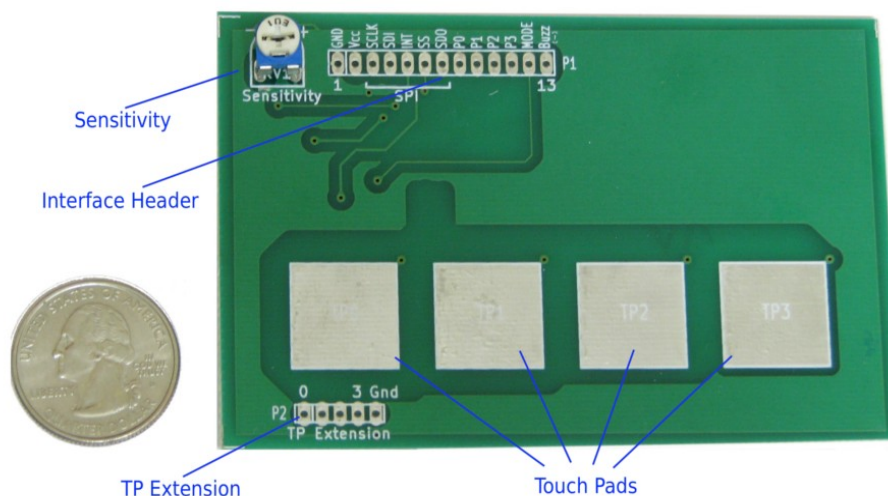

2 Specification

Features	Specification
Board	CapTouCon
Model	TP40201
Operating Voltage	5V DC
Touch Interface	4 Touch Pads
Sensitivity Control	Yes
Parallel Interface	Yes(on Header)
Serial SPI Interface	Yes
Buzzer Interface	Yes
TP Extension	Yes
Toggle Mode	Yes
Multi Touch	Yes (Up-to 4 buttons)
Weight	22 gm (without packaging)
Dimension	63x98x1.6 mm

3 Interface Header

Pin No	Pin Name	Description
1	GND	Ground Pin
2	Vcc	5V DC supply for board
3	SCLK	SPI Clock
4	SDI	SPI Data input
5	INT	Interrupt, active low interrupt indicating change in touch state (status register). To be used with SPI.
6	SS	SPI chip select
7	SDO	SPI Data out
8	P0	Pin on header interface for Touch Pad TP0, reflects status register bit[0]. Active low.
9	P1	Pin on header interface for Touch Pad TP1, reflects status register bit[1]. Active low.
10	P2	Pin on header interface for Touch Pad TP2, reflects status register bit[2]. Active low.
11	P3	Pin on header interface for Touch Pad TP3, reflects status register bit[3]. Active low.
12	MODE	Normal mode, when tied to '1' or left open. Toggle mode when tied to '0' or GND. Normal mode is equivalent to Push Button-Switch, and Toggle mode is equivalent to On/Off switch.
13	Buzz	For Buzzer

4 Functionality

When finger is placed on “touch-pad”, CapTouCon board detects touch event and updates its internal status register. CapTouCon provides two independent ways to access internal-status register value.

Option 1: Option 1 is to use header interface. Status register bits [bit 0] directly reflects on parallel pin [P0]. Output on this interface is active low.

Option 2: Option 2 is to use SPI interface. Additional interrupt (INT) pin along with standard SPI interface (SS/Dout/Din/Clk) is provided. Interrupt (INT) pin is expected to be used with SPI interface so that any external SPI master can read status-register through SPI interface when it receives an interrupt.

In a typical setup, where SPI is used, an external SPI master is connected to CapTouCon board with SPI interface and below sequence of events are expected. Finger placed over touch-pad -> CapTouCon detects touch even and asserts interrupt (INT) pin. External master acts on the interrupt and reads the CapTouCon’s status register over SPI. CapTouCon detects SPI read and de-asserts its interrupt (INT).

As both the options are totally independent, it provides great flexibility for user to chose any or both of them. Below are some practical use-case where these can be used.

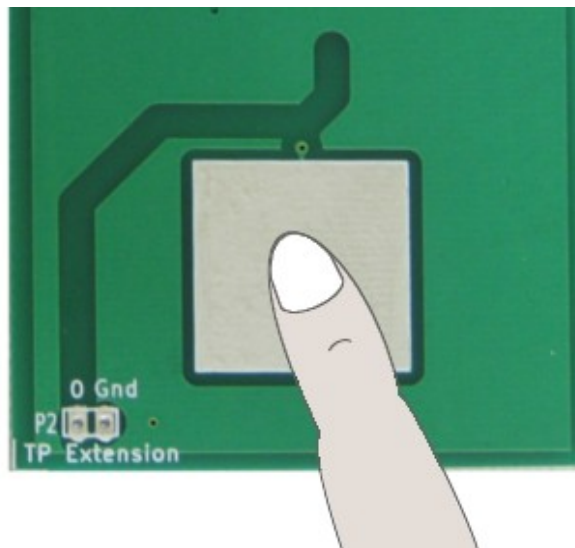

5 Header Interface

Header interface can be used directly as switch to control any device. One of the use case shown below, where a electro-magnetic relay is being used to switch on/off Bulb. MODE pin should be tied to '0' to enable toggle-mode, so that one touch will turn Bulb ON and next touch will turn it OFF.

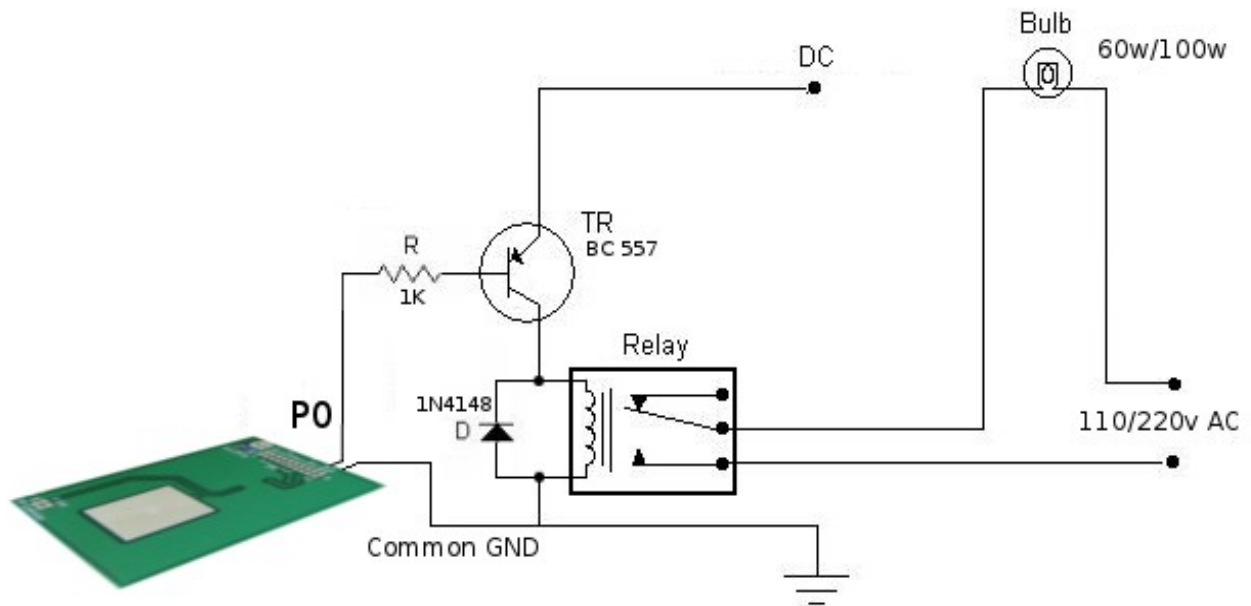

6 SPI and Header Interface

Both SPI and Header interfaces can be used together to achieve great use interaction. In a use-case shown below, CapTouCon is connected with External-SPI-Master on SPI interface and an LED is put on the header interface to give visual indication. CapTouCon always acts as SPI Slave and need be always connected with SPI-mode 0.

It is strongly recommended use transistor based driver circuit to drive LED, for simplify conceptual explanation direct connection of LDE is shown ($R = 330 \text{ Ohms}$).

INFO : SPI standard defines various clock-polarity and phases combination, and these combinations are called SPI-MODES. For any SPI-MASTER and Slave to connect properly, same SPI-MODE should be used. CapTouCon uses SPI-MODE 0. For SPI-MODE = 0, clock-polarity (CPOL/CPK) = 0 , clock-edge (CKE/NCPHA) = 1.

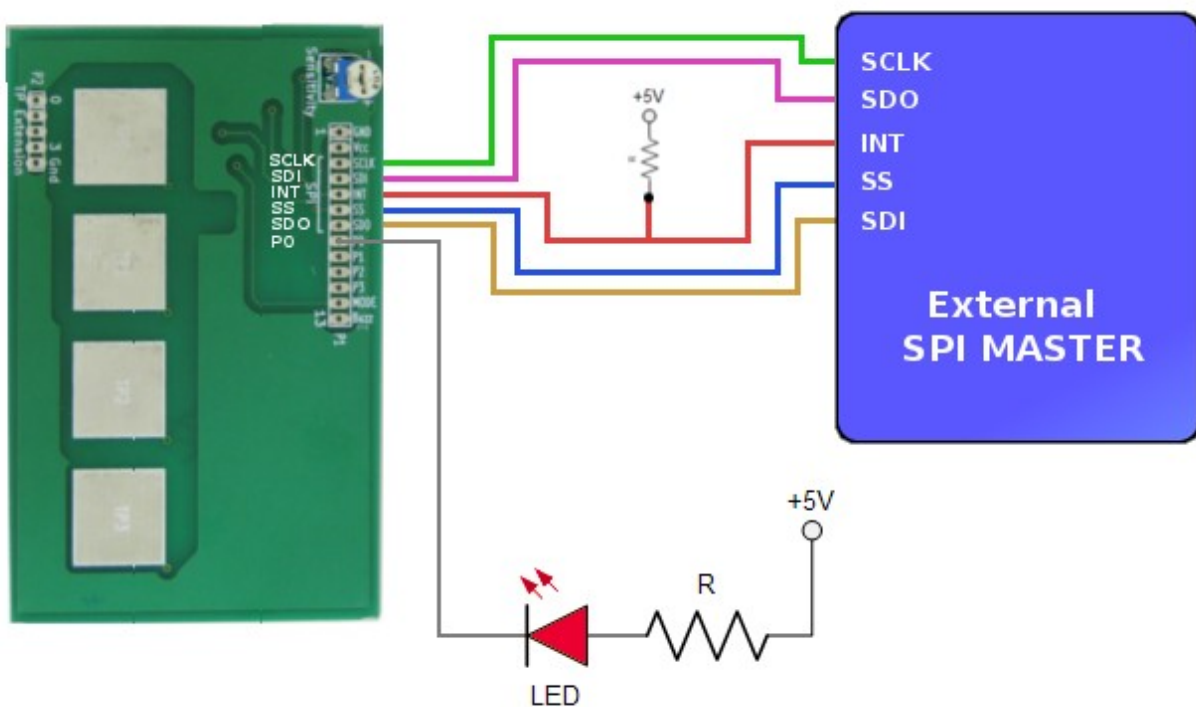

7 Interrupt

Interrupt pin INT is active low and it gets tri-stated when not active. This property enables interrupt from different CapTouCon to be combined and given as a single interrupt signal to External-SPI-Master. One external pull-up register (10K) will be needed to combine them as shown (side image). With this wired ORing of interrupt, when any of CapTouCon asserts interrupt, interrupt to External-SPI-Master gets asserted. External-SPI-Master reads status register of all CapTouCon devices over SPI to figure-out which status has changed.

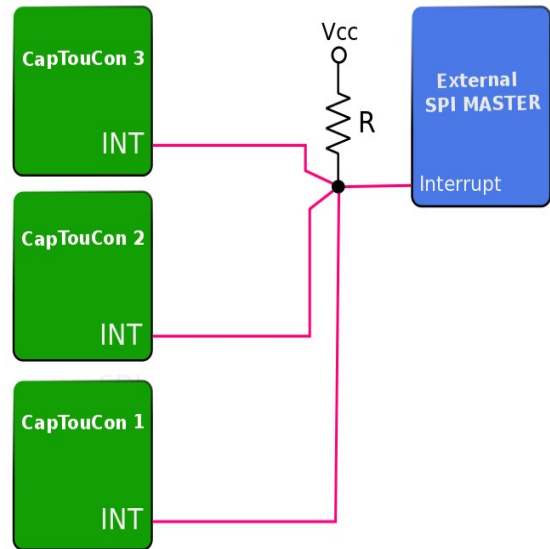

Once External-SPI-Master receives an interrupt, it should read SPI interface till interrupt is LOW, master may need to do multiple reads on SPI to do this. This is required as another touch-event might have occurred after first interrupt assertion while externa-SPI-Master still servicing the first interrupt. In this case INT pin won't get chance to assert again as it is already asserted and being serviced. Hence, after servicing the interrupt event, External-SPI-Master should check the INT pin to see if INT pins is still LOW (indicating pending touch-events to be read) and should put additional reads on SPI to read them out. This is shown as a flow diagram.

Caution : If External-SPI-Master doesn't check the INT pin again after servicing the interrupt and there is a pending touch-event yet to be read out, a dead-lock might happen.

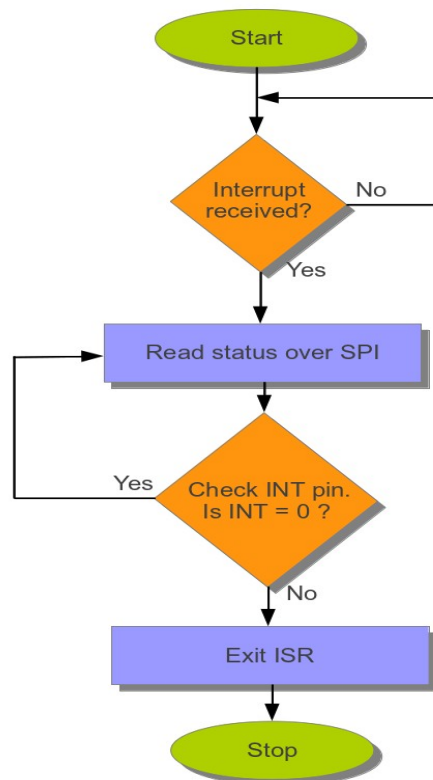

8 SPI Daisy Chain

Single SPI bus can be used to connect to number of CapTouCon devices, image below shows 7 CapTouCon board are connected in daisy-chain with one SPI interface. Connecting CapTouCon boards in daisy-chain provides immense expandability. Below image primarily shows data-flow between various CapTouCon devices when they are connected in daisy-chain, other SPI connections are not shown for simplicity. Note how data moved from one CapTouCon to another serially and finally reaches the External-SPI-Master.

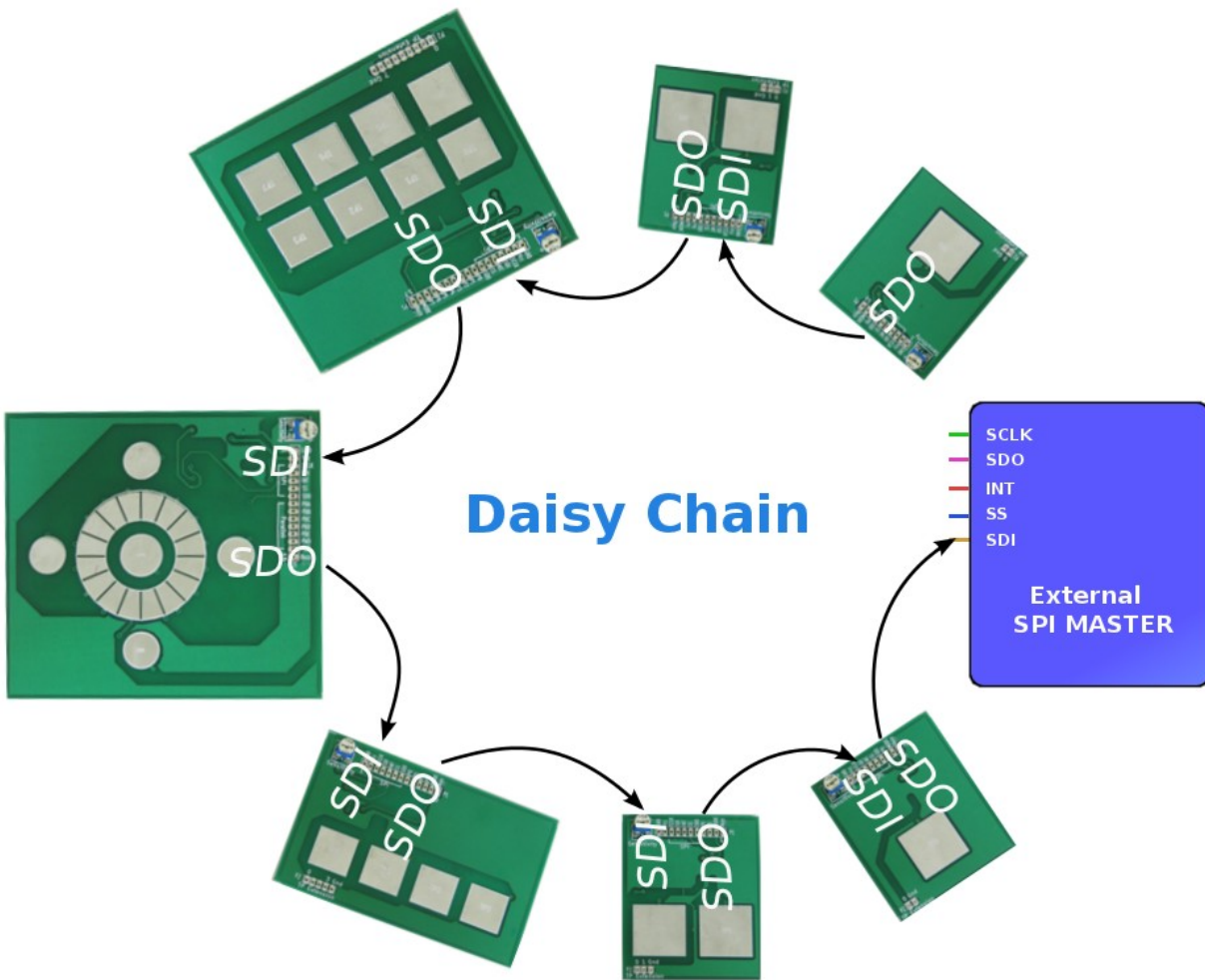

Each CapTouCon has 8-bit, when connected in daisy-chain, it is as equivalent as 7 8-bit shift registers connected serially. It is responsibility of External-SPI-Master to serially read data properly based on number of SPI-slave (CapTouCon here) present on the chain. Conceptually, master may need 16 (i.e.8x2) clocks to serial-out two SPI-Slave and 56 clocks (8x7) to serial-out seven SPI-Slaves present on the chain.

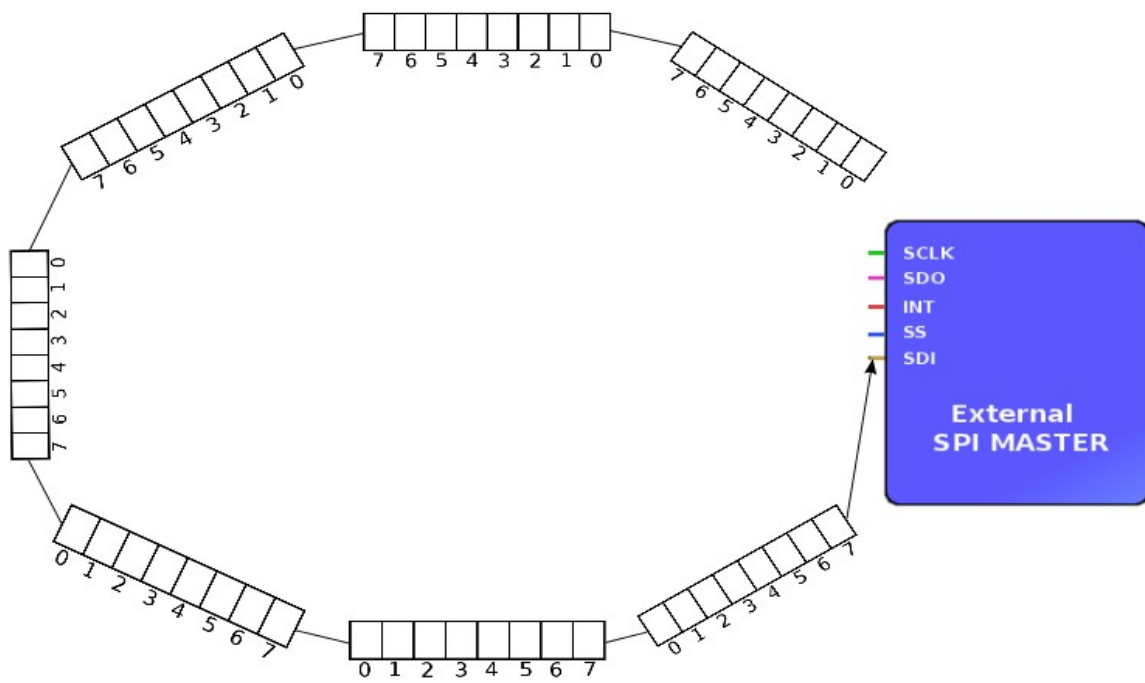
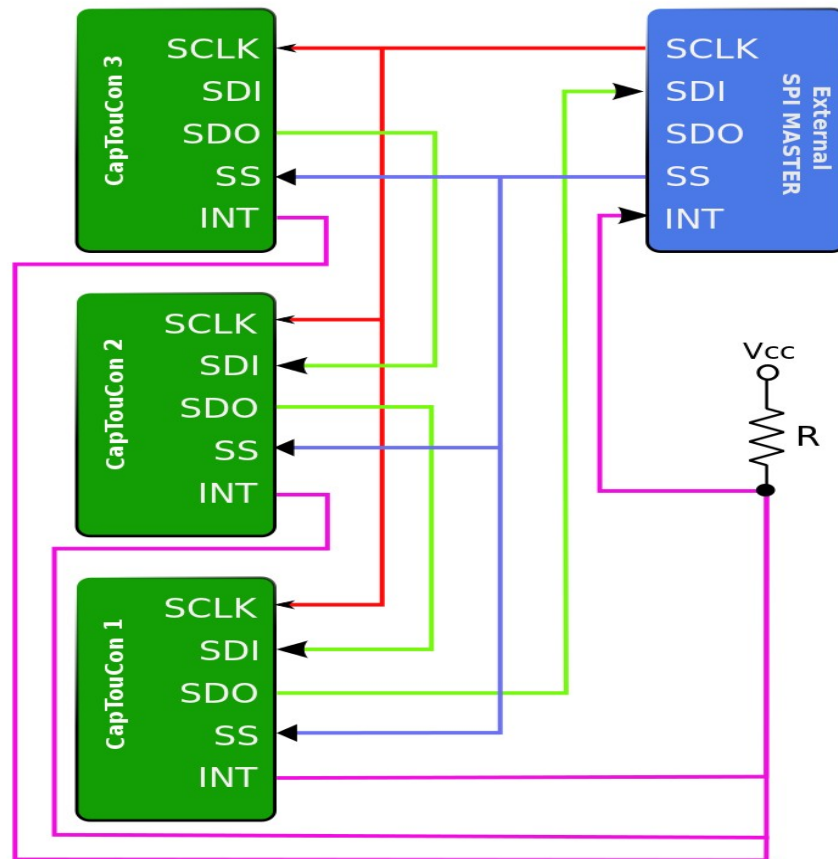

Image below shows 3 CapTouCon boards connected in daisy chain (with connection details). Clocks (SCLK) are fed to all CapTouCon, Data-out (SDO) is connected to another CapTouCon's Data-In (SDI) in chain. Chip-Select (SS) is connected to all CapTouCon.

Interrupt (INT) from all CapTouCon are connected to Master with a pull-up register. It is because, INT is active low and TRI-stated when not active. With this interrupt property interrupts from all CapTouCon can be logically ORed and fed to SPI Master. When any CapTouCon asserts interrupt, Master sees its INT input going low and it reads complete chain to check which device's status register has changed.

Note: Below is one of the implementation of daisy chain, but not the only implementation.



9 Sensitivity Control

Sensitivity of touch-pads can be controlled by using sensitivity potentiometer. Turning + side increase, and – side decreases sensitivity. User may feel need to adjust sensitivity when a sticker is put over touch-panel. CapTouCon needs restart for any change in sensitivity to come to effect. Simple way to restart is power-off and power-on.

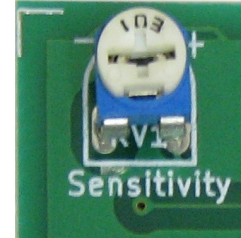

Caution : Sensitivity potentiometer is mechanical component and it is expected to be adjusted very few times over its lifetime. Frequent adjustment will result damage.

10 TP Extension

Touch-Pads extension interface is provided at the lower left corner. Idea is to extent Touch-pads present on CapTouCon to another board. It enables user to have his own custom Touch-Pads layout on external board, it provided great flexibility to design your own layout (pads position), pads size and shape. It also enables user to isolate Touch-Controller and Touch-Pads. GND (ground) pin is also provided on TP extension header along with one pin for each touch-pad.

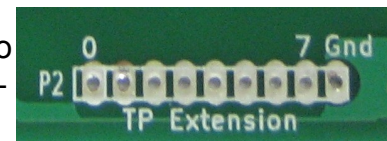

TP Extension on TP80201

In below example a external touch-pad board is connected to TP80201 CapTouCon. This extension board doesn't have any active components, just pads and the header connector. Special consideration should be done for the wires connecting two boards, they should be as small as possible, should not overlap and physically independent. Gnd pin must always be used properly. Users may design and order their own external Touch-Pad extension board using on-line tool “TPB Designer” at www.sigmatone.com.

Note : On-board CapTouCon Touch-Pads will always be active along with the external Touch-Pads. Though, user may chose to adjust “Sensitivity” as per the extension board requirement.

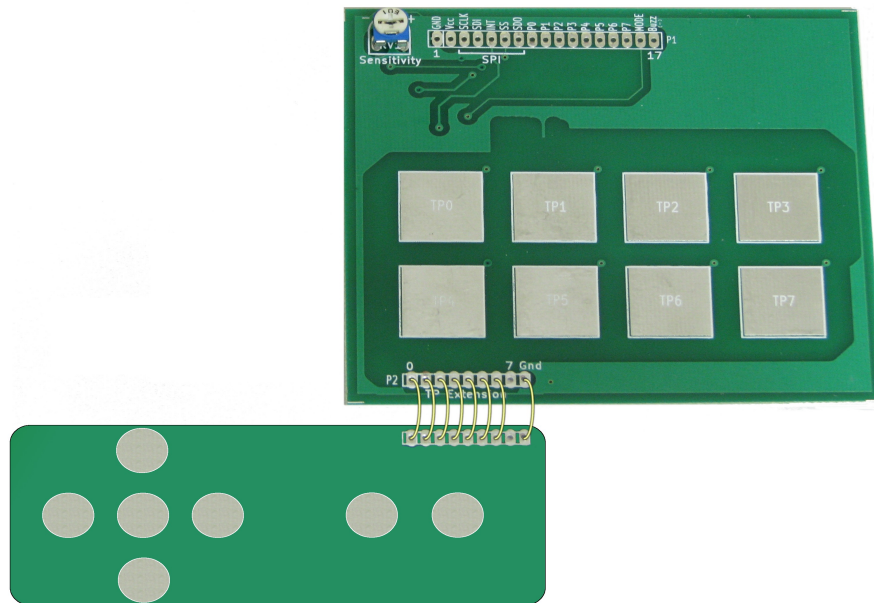

Touch pads extension using external pads board

11 MODE

CapTouCon boards supports two modes, mode 0 and mode 1. When MODE pin is connected to Gnd, it is mode 0 and when MODE pin is connected to Vcc, it is mode 1. When MODE pins is left un-connected, it is mode 1.

MODE 0 : This mode is also called Toggle mode, in this mode every time any pad is touched, the corresponding status register bit toggles which also reflects on the parallel interface. This mode is useful for implementation of On/Off switch. So that with one touch the device under operation can be switched-on and on another touch it will be switched-off. Section 6 “**Use-Case – Header Interface:**” describes the simplest use-case.

MODE 1 : In this mode, status register bit will remain asserted till finger is placed on the corresponding touch-pad, as the finger is left, the register bit dis-asserts. Same reflects on the parallel interface. This mode is analogous to push-button-switch. This mode can be useful in door-bell like implementation, where the bell needs to ring till pad is being touched.

12 Buzzer

A Buzzer pin (Buzz) is provided to connect Buzzer as shown below. It generates beep on every touch.

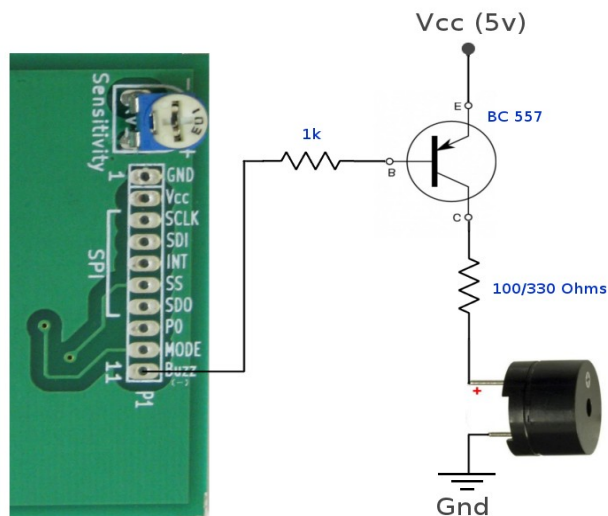

Buzzer connection example using TP10201

TIP : It is strongly recommended to use transistor circuit to drive Buzzer, but for testing purpose one can connect Buzzer's + pin to Vcc and another pin to CapTouCon as shown below. User may observe non linear beep tones if buzzer is driven directly.

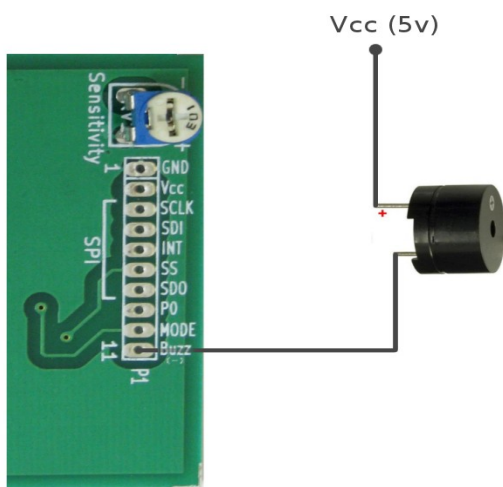

Buzzer directly driven by CapTouCon, for testing purpose only.

Common Buzzer can be used for multiple CapTouCon boards, as shown below.

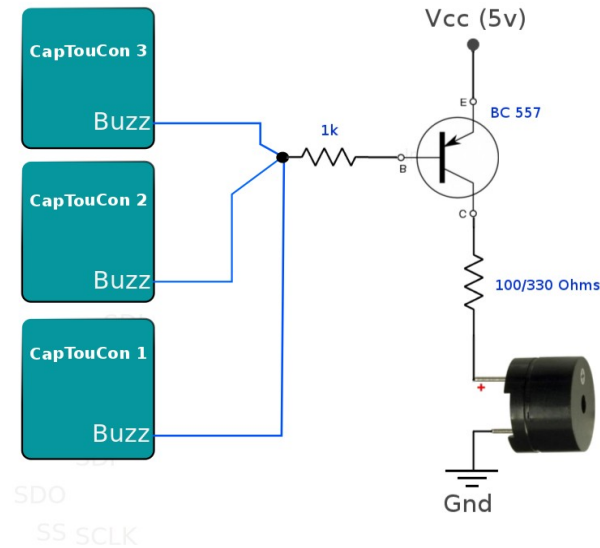

TIP : Again, It is strongly recommended to use transistor circuit to drive Buzzer, but for testing purpose one can connect common single Buzzer with multiple CapTouCon boards as shown below. User may observe non linear beep tones if buzzer is driven directly.

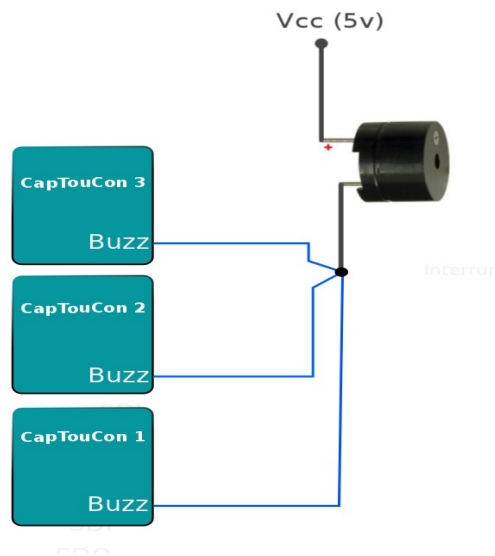

13 Timing Waveforms

Below timing waveforms are captured with TP80201 device. It shows INT and SPI signals timing relationship for various touch events. Note TP80201 has eight touch pads.

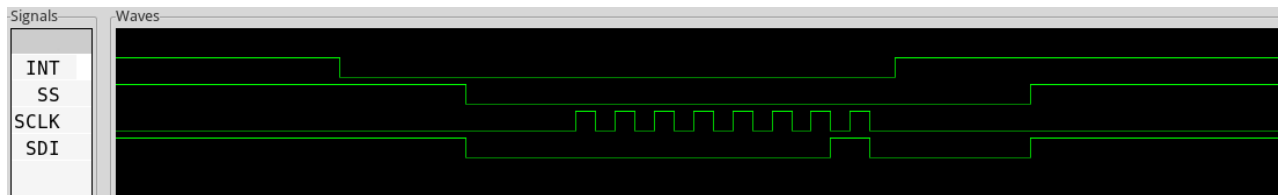

1. Illustration: TP0 Pressed, Status bit 0 gets set, status 0x1 is transferred over SPI

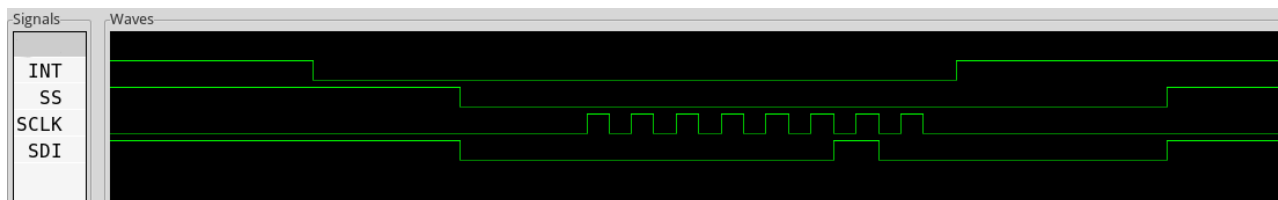

2. Illustration: TP1 Pressed, Status bit 1 gets set, status 0x2 is transferred over SPI

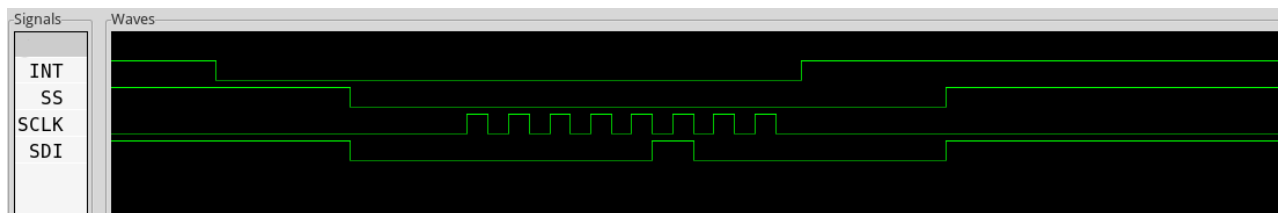

3. Illustration: TP2 Pressed, Status bit 2 gets set, status 0x4 is transferred over SPI

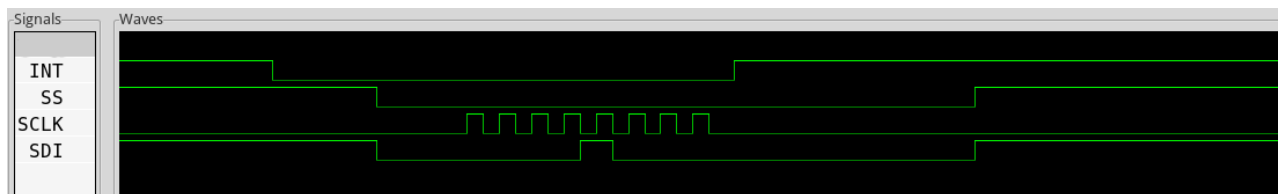

4. Illustration: TP3 Pressed, Status bit 3 gets set, status 0x8 is transferred over SPI

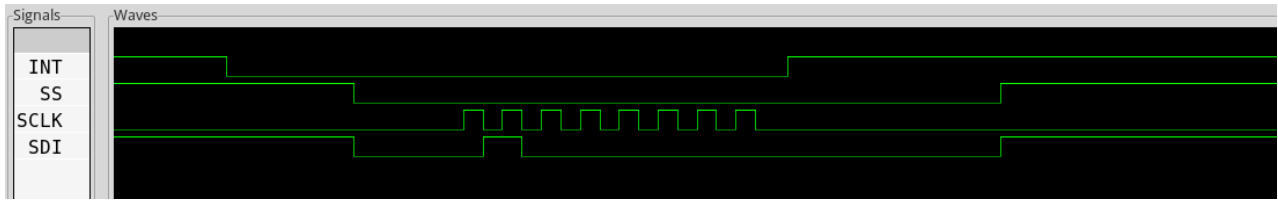

5. Illustration: TP6 Pressed, Status bit 6 gets set, status 0x40 is transfered over SPI

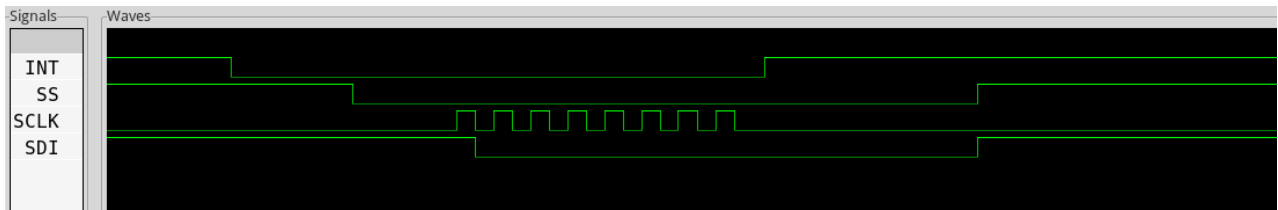

6. Illustration: TP7 Pressed, Status bit 7 gets set, status 0x80 is transfered over SPI

14 Timing Waveforms (Daisy Chain)

Below timing waveforms are captured with three devices connected in daisy chain over SPI. Device 1 is TP80201, Device 2 is TP20201 and Device 3 is MM50201. It shows INT and SPI signals timing relationship for various touch events on various devices. Note how on an interrupt, SPI Masters puts 3 SPI reads to get status data from all 3 devices present on daisy chain. Also note SS (Chip select) is asserted for all 3 reads.

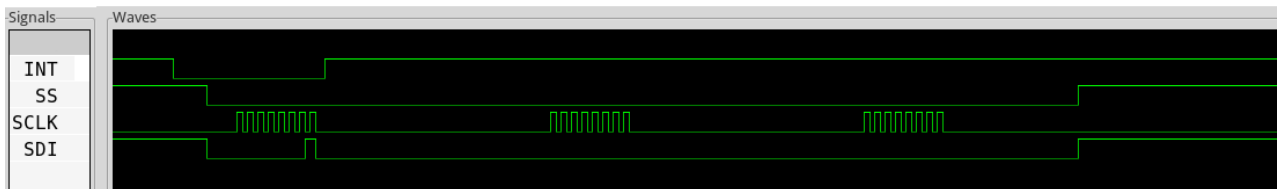

7. Illustration: TP0 of Device1 Pressed, Status bit 0 of Device 1 gets set, status 0x1 0x0 0x0 transfered over SPI

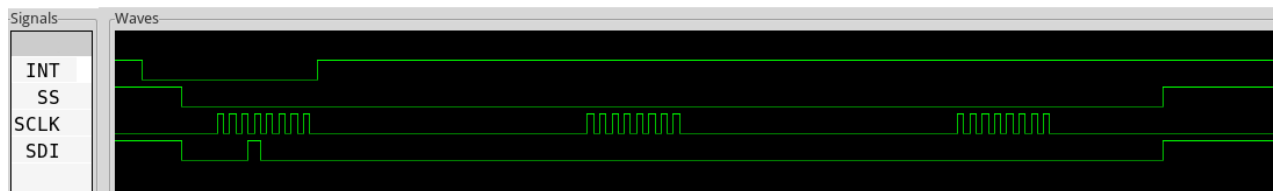

8. Illustration: TP4 of Device 1 Pressed, Status bit 4 of Device 1 gets set, status 0x10 0x0 0x0 transferred over SPI

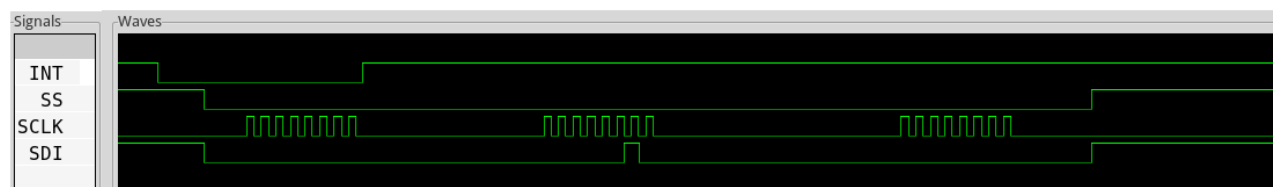

9. Illustration: TP1 of Device 2 Pressed, Status bit 1 of Device 2 gets set, status 0x0 0x2 0x0 transferred over SPI

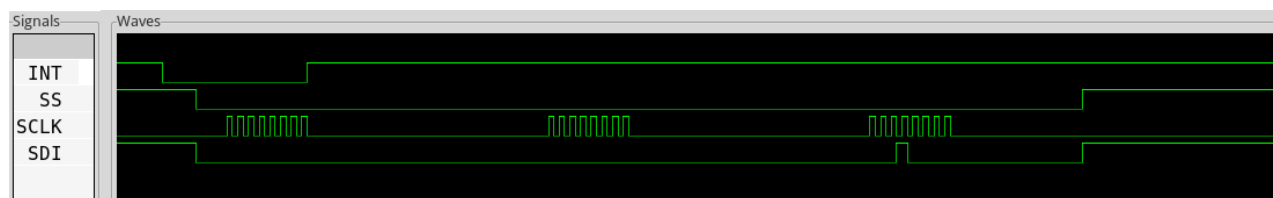

10. Illustration: Pad C of Device 3 Pressed, Status bit 5 of Device 3 gets set, status 0x0 0x0 0x10 transferred over SPI

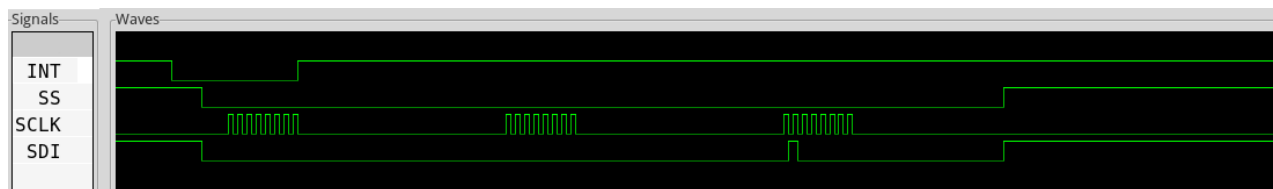

11. Illustration: Pad E of Device 3 Pressed, Status bit 7 of Device 3 gets set, status 0x0 0x0 0x40 transferred over SPI

15 FAQ

Q : What SPI mode should be used by External-SPI master to connect to CapTouCon?

A: Use SPI MODE 0. For SPI-MODE = 0, clock-polarity (CPOL/CPK) = 0 , clock-edge (CKE/NCPHA) = 1. This is not configurable and not changeable.

Q : CapTouCon is Slave or Master on the SPI bus?

A: CapTouCon is always Slave.

Q: Can INT pin used along with Header interface.

A: INT is meant to be used with SPI interface.

Q: Can unused pins be left unconnected?

A: Yes.

Q: How many devices can be connected in daisy chain?

A: Theoretically there is no limitation and fairly large number of devices can be connected.

Q: I am driving buzzer directly, but the sound is not linear.

A: Direct driving buzzer is recommended only for testing purpose, buzzer should be driven by transistor circuit as shown in this document.

Q:Can I put a potentiometer in series with Buzzer to control its volume?

A: Yes.

Q: What is parallel interface?

A: Parallel interface is set of pins on header interface on which status register bits are directly mapped.

16 Support/Feedback

Feel free to provide feedback on this document for improvements, please drop us an email at support@sigmatone.com. Feel free to discuss technical issues related to Sigmatone products at Sigmatone forums.